

**1 VISTA-355_AC
36x54 (WITHOUT HELPER)**

NOTE
 1. PROVIDE 100 lx MIN. LIGHTING TO THE WHOLE PLATFORM (BY ELECTRICIAN).
 2. ANY WALL LOCATED LESS THAN 12" (WITHOUT HELPER) OR 24" (WITH HELPER) AWAY FROM THE CAB MUST EXCEED THE UPPER LANDING HEIGHT BY AT LEAST 42". IT MUST BE SMOOTH (NO RECESSES OR PROTRUSIONS).

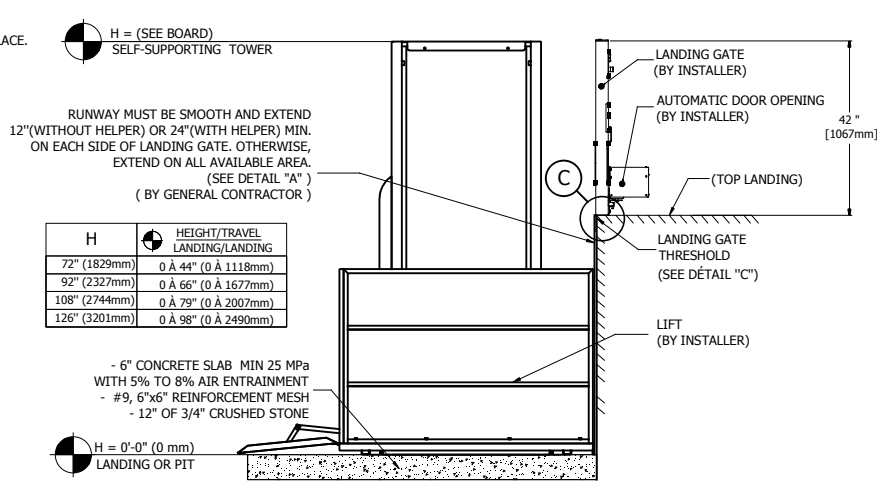

**3 DETAIL B
FLOOR ELEVATION**

H	HEIGHT/TRAVEL LANDING/LANDING
72" (1829mm)	0 Å 44" (0 Å 1118mm)
92" (2327mm)	0 Å 66" (0 Å 1677mm)
108" (2744mm)	0 Å 79" (0 Å 2007mm)
126" (3201mm)	0 Å 98" (0 Å 2490mm)

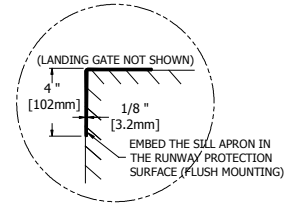

4 DETAIL C

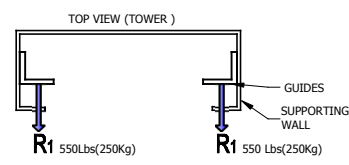

5 RAIL REACTIONS

VISTA_355 TECHNICAL DATA	
TYPE	Outdoor use, vertical lift, open shaft
CODE	CSA/B355-09
MAX CAPACITY	One person a wheelchair or One person a wheelchair and one helper
MAX LOAD	750 lb (340 Kg)
RAIL LINEAR WEIGHT	5 lb/ft
TRACTION MACHINE	Acme screw and nut
ALIMENTATION	DC, 24 VOLT
VELOCITY	9 ft/min (0.05 m/s) *option max speed: 14 ft/min (0.07 m/s)
MAX TRAVEL	98 in (2500 mm) max.
EMERGENCY BRAKES	Bronze safety nut
CAB FINISH	See document C-02
LIFT CAB	Max floor dimensions 40 x 66 in (1018 mm x 1679 mm)
FLOOR FINISH	Anti-skid floor surface
CONTROL BUTTONS	Weatherproof control buttons
CONTOLER	BECVISZ3 (CSA/LR45147)
DOOR INTERLOCK	HONEYWELL (REALIGN) or GAL (TYPE N)

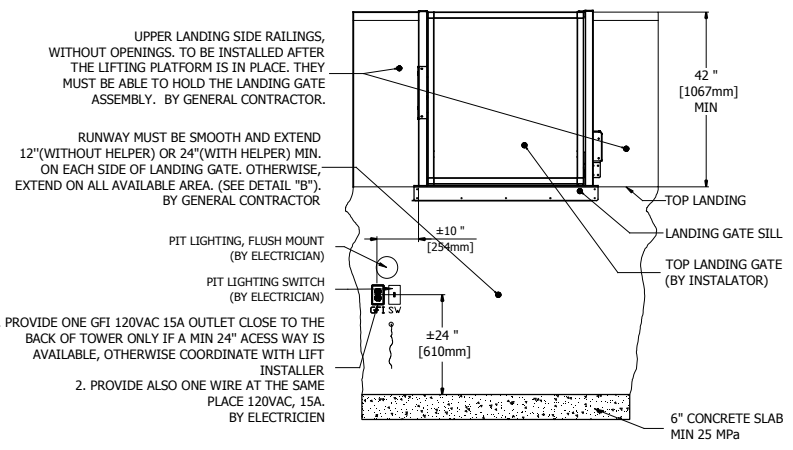
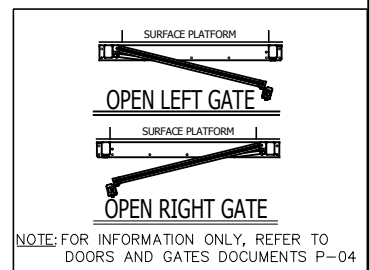

**2 DETAIL A
SIDE VIEW**

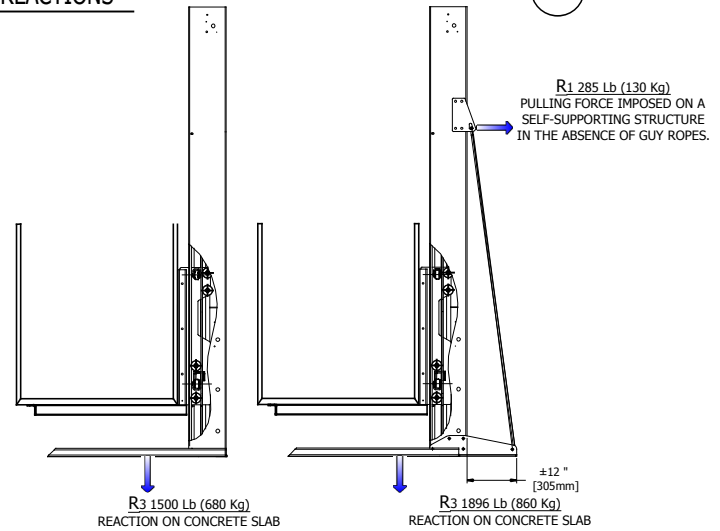

**5 VISTA 750 Lb
REACTIONS**

**6 VISTA 1000 Lb
REACTIONS**

NOTE
 -THIS ELECTRONIC DOCUMENT IS NOT SIGNED OR SEALED BY AN ENGINEER AND MAY NOT BE USED FOR CONSTRUCTION PURPOSES.
 -THIS ELECTRONIC DOCUMENT IS STRICTLY FOR INFORMATION PURPOSES (OR COORDINATION, AS APPLICABLE).
 -NO GUARANTEES ARE GIVEN ON THE INTEGRITY OF THE TRANSMITTED INFORMATION.
 -NO GUARANTEES ARE GIVEN ABOUT PAST OR FUTURE CHANGES TO THIS DOCUMENT

NOTE
 LIFT NOT SHOWN FOR CLARITY PURPOSE OF THE DRAWING.

Les Escalateurs Atlas Inc.
 8255 Boul. Laframboise
 St-Hyacinthe (Québec)
 J2R 1E8, Canada
 Tél: (450) 796-5708
 Fax: (450) 796-5110

GÉNÉRALES INFORMATIONS		
NO. DRAWING VISTA_AC	DATE: 26/01/2016	REVISION
CODE: B355	DRAFTER: M.Debusschere	No SHEET: 1/1