

**1 VISTA-613-AC  
36x54 (WITHOUT HELPER)**

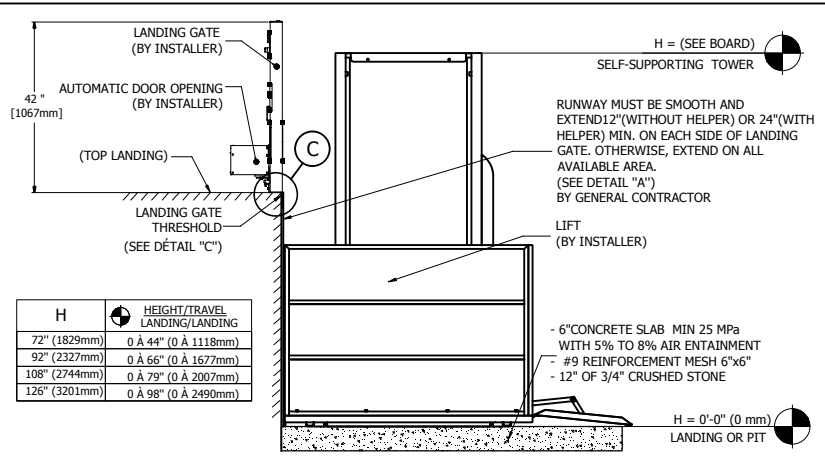

**3 DETAIL B  
FLOOR ELEVATION**

**NOTE**  
1. PROVIDE 100 lx MIN. LIGHTING TO THE WHOLE PLATFORM (BY ELECTRICIAN).  
2. ANY WALL LOCATED LESS THAN 12" (WITHOUT HELPER) OR 24" (WITH HELPER) AWAY FROM THE CAB MUST EXCEED THE UPPER LANDING HEIGHT BY AT LEAST 42". IT MUST BE SMOOTH (NO RECESSES OR PROTRUSIONS).

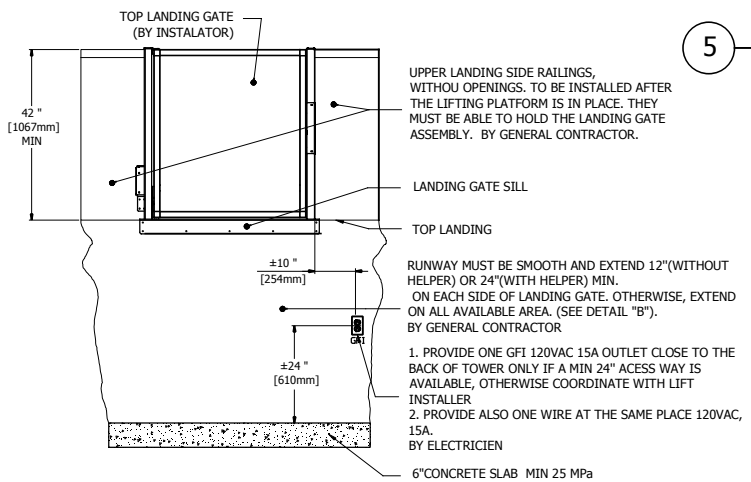

**2 DETAIL A  
SIDE VIEW**

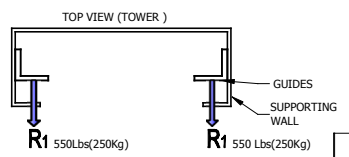

**5 RAIL REACTIONS**

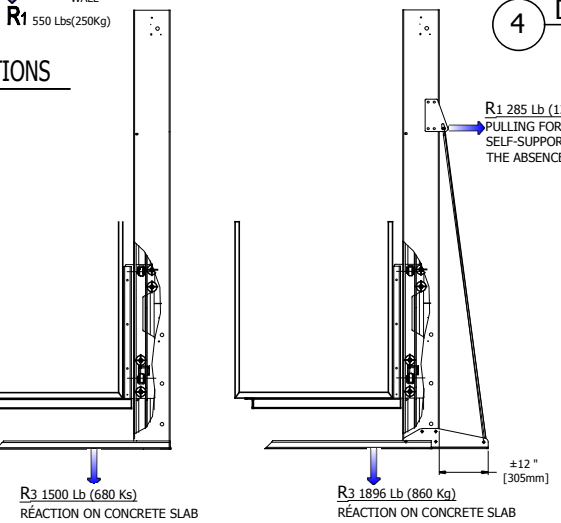

**6 VISTA 1000 Lb  
REACTIONS**

**5 VISTA 750 Lb  
REACTIONS**

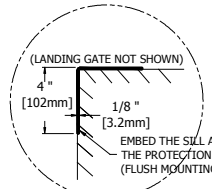

**4 DETAIL C**

VISTA_613 TECHNICAL DATA	
TYPE	Outdoor use, vertical lift, open shaft
CODE	CSA/B613
MAX CAPACITY	One person a wheelchair or One person a wheelchair and one helper
MAX LOAD	750 Lb(340 Kg)
RAIL LINEAR WEIGHT	5 Lb/ft
TRACTION MACHINE	Acme screw and nut
ALIMENTATION	DC, 24 VOLT
VELOCITY	9 pi/min(0.05m/s) *option max speed: 14pi/min(0.07m/s)
MAX TRAVEL	98po (2500 mm) max.
EMERGENCY BRAKES	Bronze safety nut
FINI DE LA CABINE	See document C-01
CABINE	Max floor dimensions 40x66po (1018mm x1679mm)
FINI DU PLANCHER	Anti-skid floor surface
CONTROL BUTTONS	Weatherproof control buttons
CONTOLEUR	BECVIS23 (CSA/LR45147)
DOOR INTERLOCK	HONEYWELL (RELIALIGN) or GAL (TYPE N)

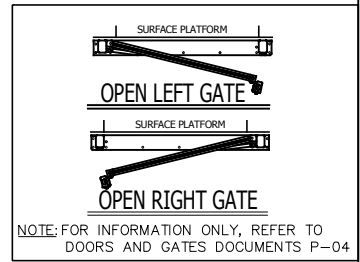

**NOTE**  
-THIS ELECTRONIC DOCUMENT IS NOT SIGNED OR SEALED BY AN ENGINEER AND MAY NOT BE USED FOR CONSTRUCTION PURPOSES.  
-THIS ELECTRONIC DOCUMENT IS STRICTLY FOR INFORMATION PURPOSES (OR COORDINATION, AS APPLICABLE).  
-NO GUARANTEES ARE GIVEN ON THE INTEGRITY OF THE TRANSMITTED INFORMATION.  
-NO GUARANTEES ARE GIVEN ABOUT PAST OR FUTURE CHANGES TO THIS DOCUMENT

**Les Escalateurs Atlas Inc.**  
8255 Boul. Laframboise  
St-Hyacinthe (Québec)  
J2R 1E8, Canada  
Tél: (450) 796-5708  
Fax: (450) 796-5110

GÉNÉRAUX INFORMATIONS		
No. DRAWING	DATE:	REVISION
VISTA_AC	XX/XX/2015	
CODE:	DRAFTER:	No SHEET:
B355	M.Debusschere	1/1